

PED-Board V5

For National Instruments System on Module - sbRIO-9651®

Key Technical Features:

- Fully programmable using LabVIEW®
- Peripheral support via dedicated LabVIEW® drivers
- Includes fully editable demo programs for accelerated development
- Implementation of high-performance real-time control algorithms
- High-speed data acquisition and high-throughput processing capabilities
- Advanced power electronic converters and electric drive support

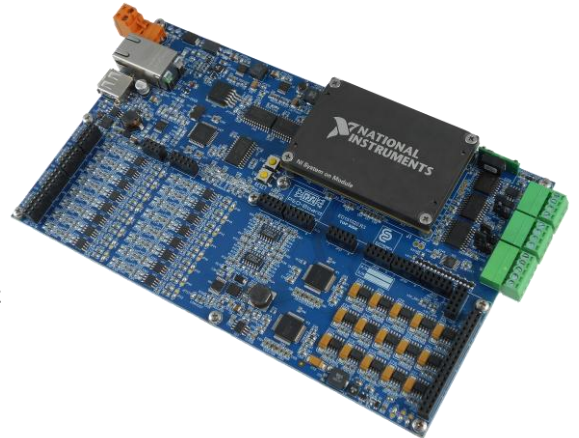

30 x PWM

- 0V↔15V or 0V↔5V selectable output voltage
- Direct LED driving capability for optocoupled gate driver
- Additional PWM channels available through the Digital I/O interface

8 x 14-bit Low-Pass Filtered ADC – (ADC1)

- Simultaneous sampling
- 1,45 μs conversion time
- Differential input: configurable -5V ↔ 5V or 0V↔10V inputs
- Second order low-pass Butterworth active filter with configurable cut-off frequency (factory default 20 kHz)

8 x 14-bit ADC – (ADC2)

- Simultaneous sampling
- 1,45 μs conversion time
- Differential input: configurable -5V ↔ 5V or 0V↔10V configurable inputs

8 x 10-bit ADC – (ADC3)

- Asynchronous sampling
- Up to 200 kS/s
- 0V↔5V input

4 x 12-bit DAC

- Digital-to-analog converter with 7 μs settling-time
- Isolated, no ground loops

46 x 3.3V Digital I/O

- Suitable for Hall-effect position sensors interface, Encoder interface, Relay control, Additional PWMs, General purpose I/O, Additional CAN controller, among others

1 x RS-485

- Isolated transceiver
- half-duplex and full-duplex communication

1 x CAN-bus

- 2.0A and 2.0B support
- Isolated transceiver
- Up to 1 Mbit/s

Resolver interface

- Fully configurable electrical interface
- Speed and position measurement
- Resolver fault detection

Ethernet port

- For programming, debugging and operation

USB port

Lithium battery for the Real-Time clock (RTC Battery)

Custom configuration for scaling circuits, filtering and default setup for orders of 5 units or more

Characteristics

Input voltage supply (V_{in})*	+12V \pm 10% (No reverse voltage protection)
Input current	2,5A (maximum current at V_{in})
Storage temperature (IEC 60068-2-1, IEC 60068-2-2)	-40 to 85 °C
Operating temperature	-25 to 60 °C
Operating humidity (IEC 60068-2-56)	10 to 90% RH, noncondensing
Storage humidity (IEC 60068-2-56)	5 to 95% RH, noncondensing
Maximum altitude	5000 m
Pollution Degree (IEC 60664)	2
Analog inputs AINx (ADC1, ADC2) max voltage	\pm 11V
Analog inputs AINx (ADC3) max voltage	+5.1V

*Do not apply an input voltage higher than 14V at the V_{in} terminal with respect to GND

Functional block diagram

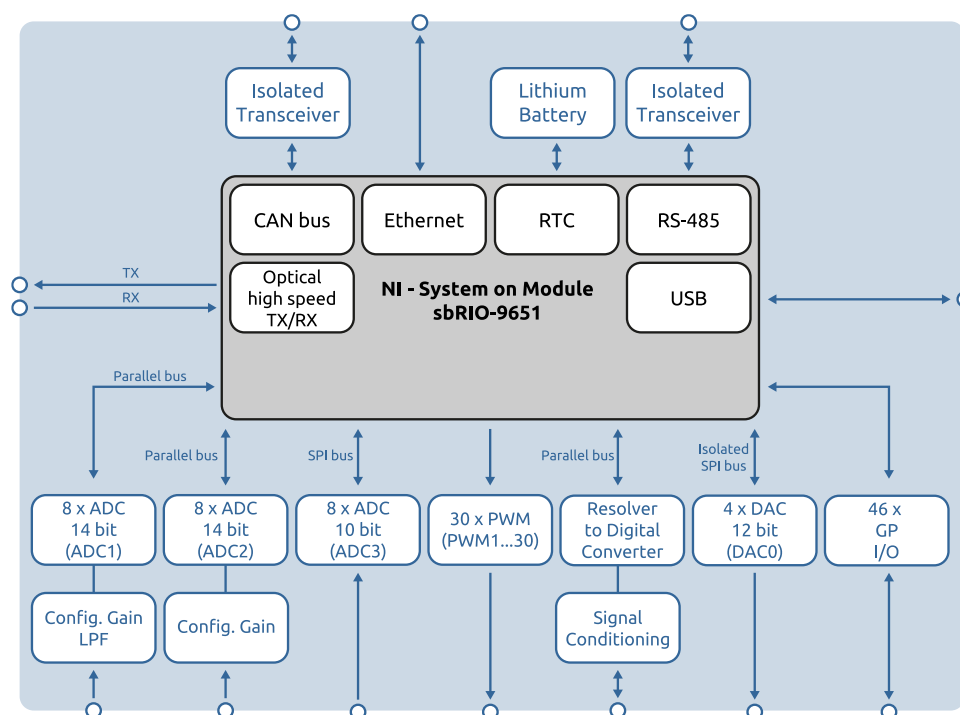

Mechanical layout

